

外視 / External view

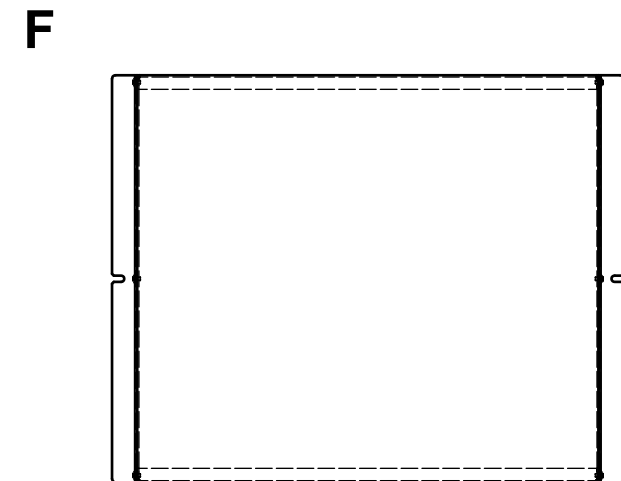

構成内容 / Components				
No.	名称 / Part name	数量 / Pcs	材質 / Material	色・表面処理 / Color・Finish
1	カバー Cover	1	アルミ板 A1100P t1.5 Aluminium A1100P t1.5	表面 メタリックシルバー塗装, 裏面 導通処理 Metallic silver painted, Inside Conductivefinished
2	シャーシ Base	1	アルミ板 A1100P t1.5 Aluminium A1100P t1.5	表面 メタリックシルバー塗装, 裏面 導通処理 Metallic silver painted, Inside Conductivefinished
3	取付ビス(トラスM3 x 5) Screw(Truss head M3 - 5)	6	真ちゅう Brass	ニッケルメッキ Nickel Plated
4	ワッシャー(M3用) Washer(M3)	6	真ちゅう Brass	ニッケルメッキ Nickel Plated

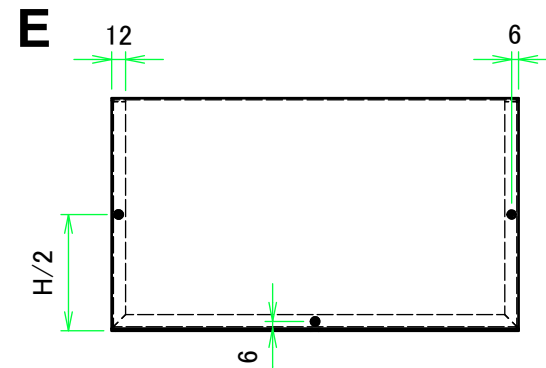
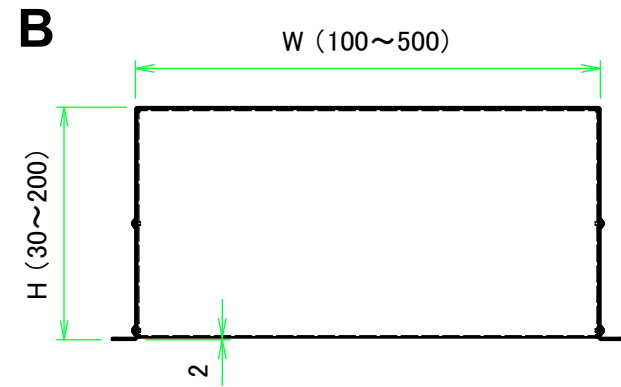
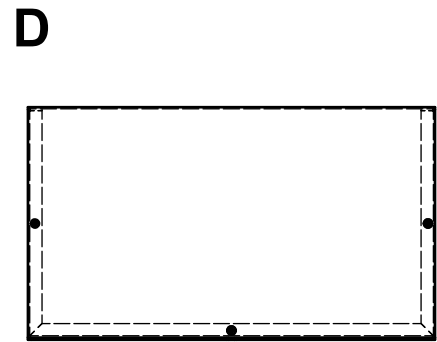
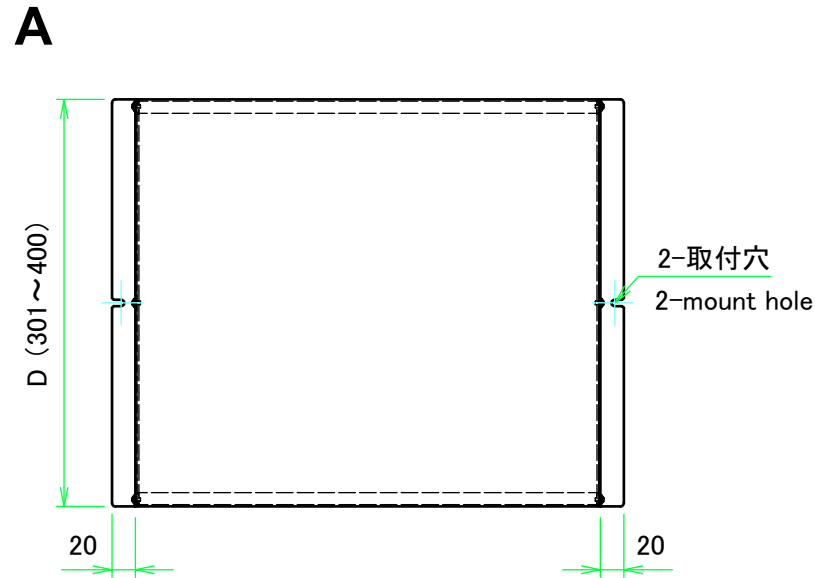
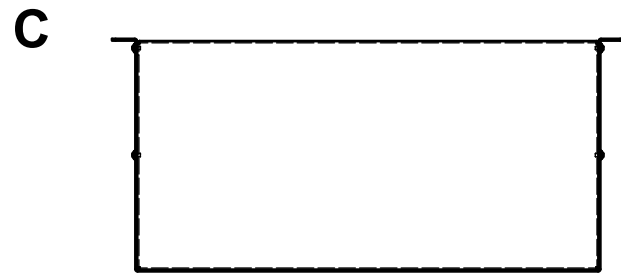
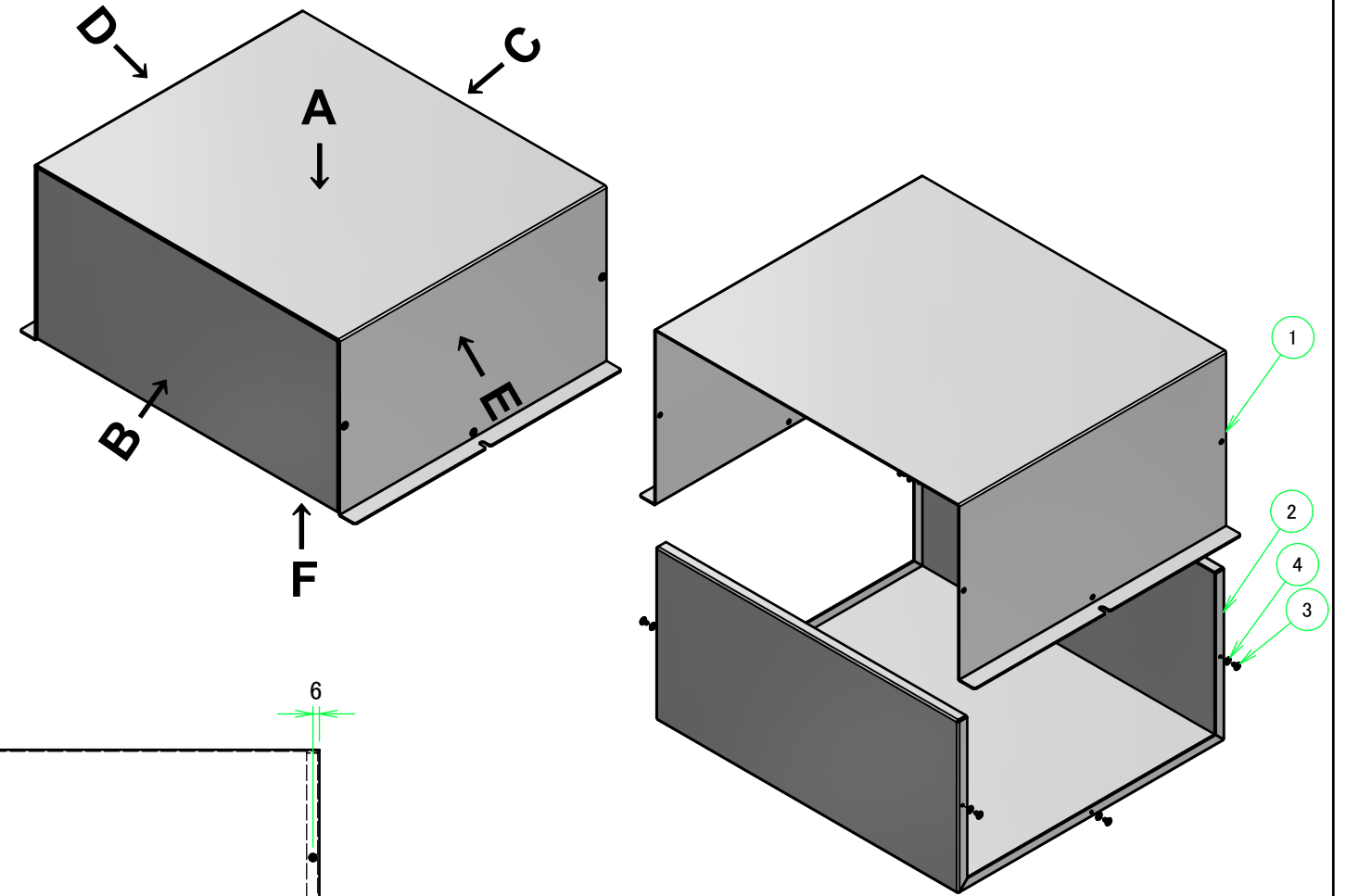

ケース型番 / Product Number

MBCF - - B 15 - 2

W H D シャーシタイプ・板厚 (補強あり・t1.5) 取付穴数 (mount hole)

Base type・thickness (reinforced・t1.5)

W・H・D 寸法制限範囲 / Dimension limit range		
W	H	D
100~500	30~200	301~400

* ケース寸法範囲内でも対応できない場合があります。詳細はカタログ内価格表でご確認ください。
 * Size combinations available will vary based on each base type. For more information, refer to our catalog, or inquire.

株式会社タカチ電機工業 TAKACHI ELECTRONICS ENCLOSURE CO., LTD.		品名/Title フランジ足付アルミフリーサイズケース CUSTOM DIMENSIONS CASE	尺度/Scale 1:6.5
承認/Approved 中根	検図/Checked 大江	製図/Created 横田 型番/Product number MBCF□-□-□ B15-2(D≥301)	
作成日/Date 2019/06/26			1 / 3

カバー / Cover

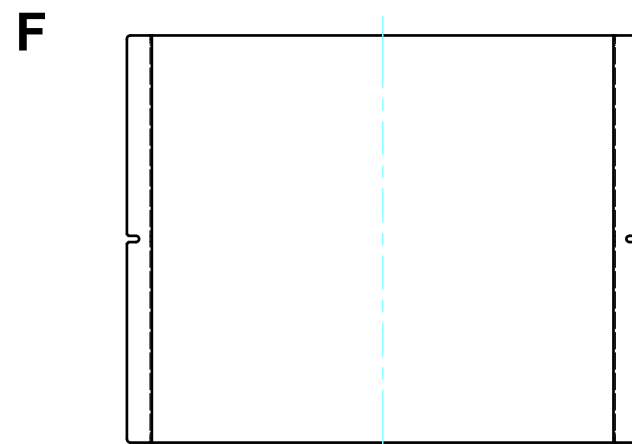
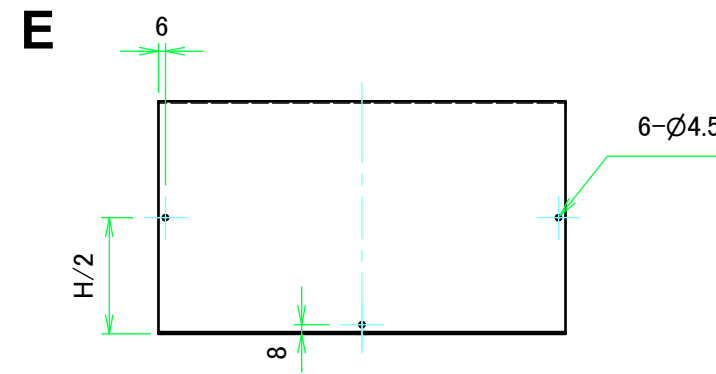
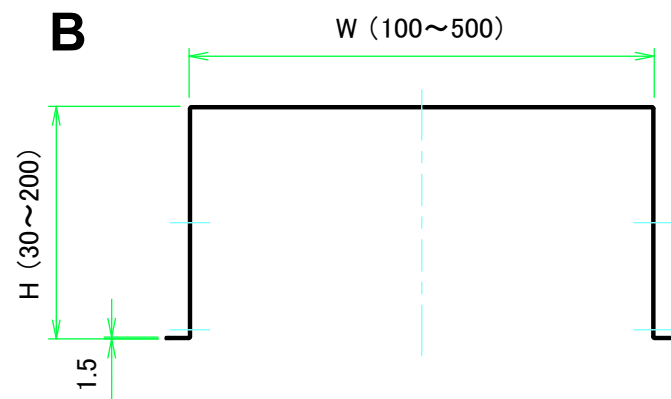
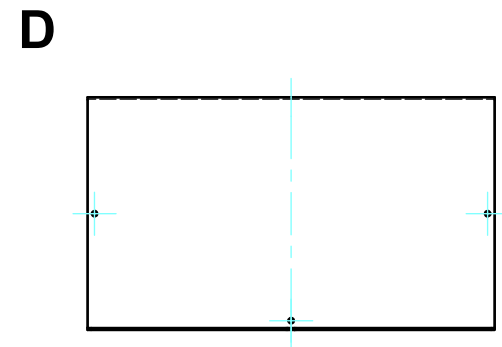
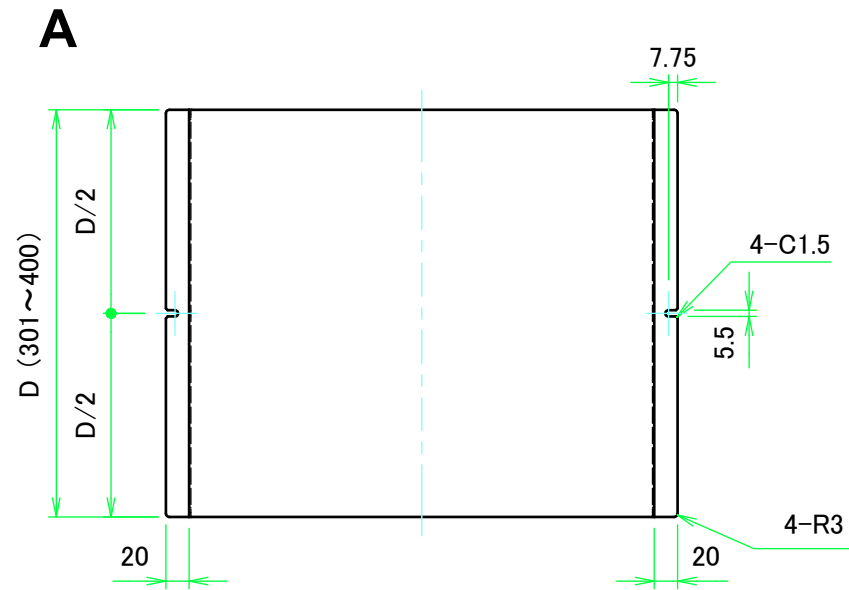
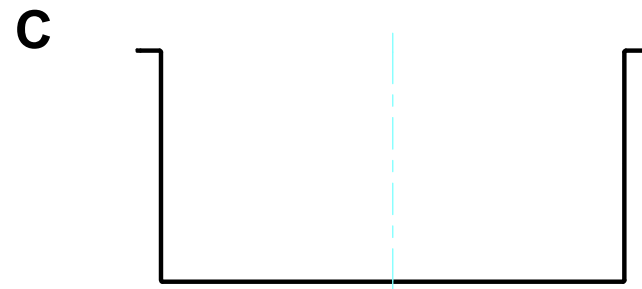

株式会社タカチ電機工業 TAKACHI ELECTRONICS ENCLOSURE CO., LTD.			品名/Title フランジ足付アルミフリーサイズケース CUSTOM DIMENSIONS CASE	尺度/Scale 1:6.5
承認/Approved	検図/Checked	製図/Created	型番/Product number MBCF□-□-□ B15-2 (D ≥ 301)	
中根	大江	横田	作成日/Date 2019/06/26	2 / 3

シャーシ / Base

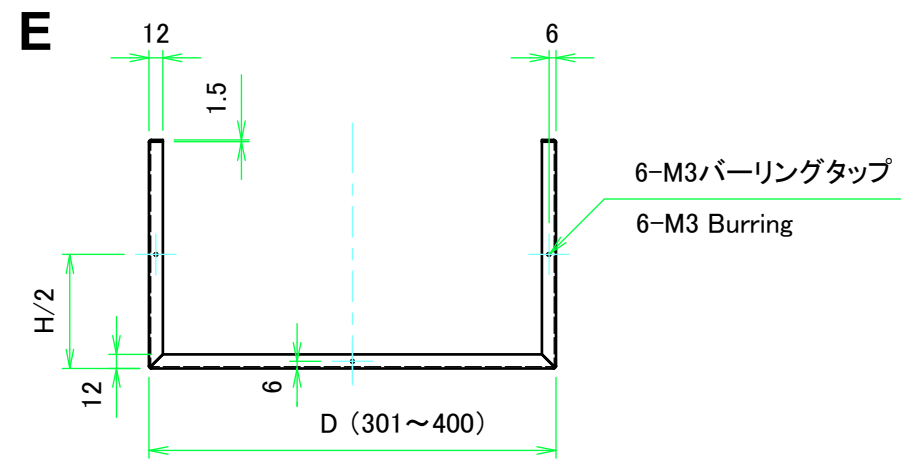
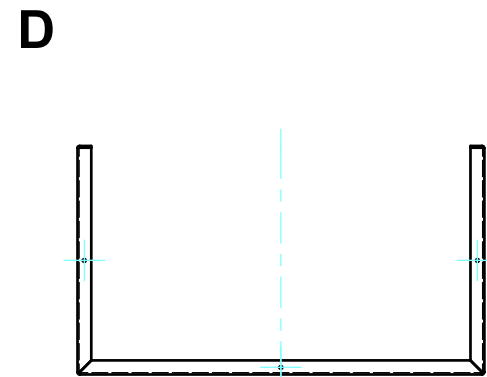
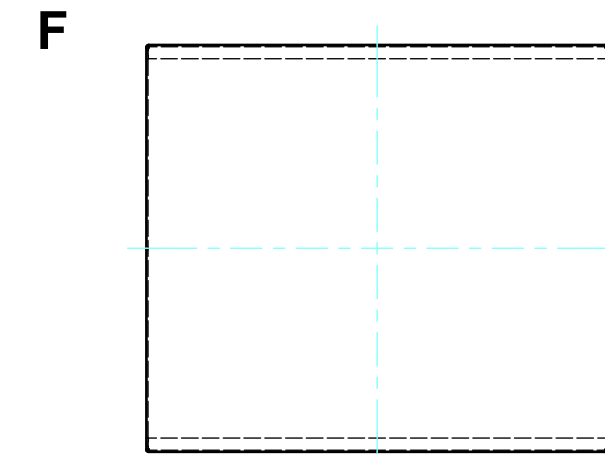
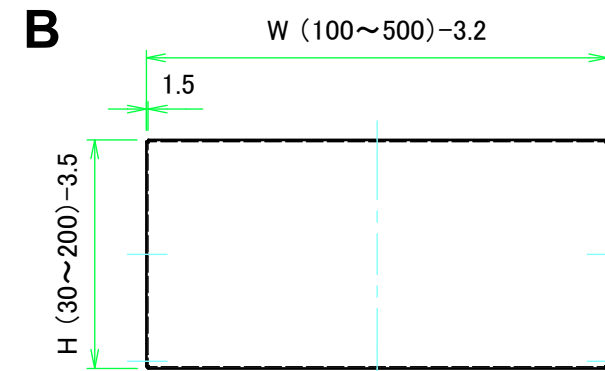
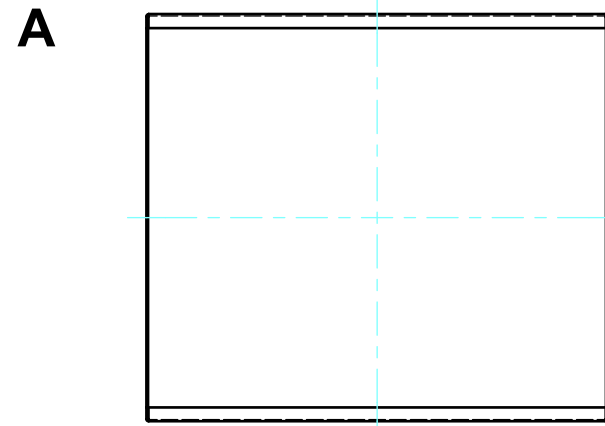
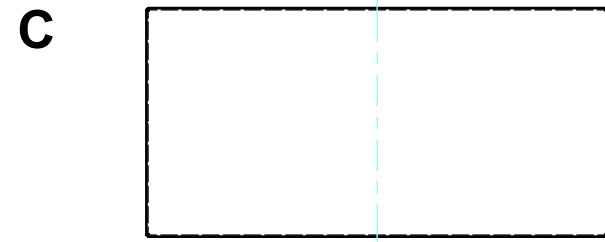

株式会社タカチ電機工業 TAKACHI ELECTRONICS ENCLOSURE CO., LTD.			品名/Title フランジ足付アルミフリーサイズケース CUSTOM DIMENSIONS CASE	尺度/Scale 1:6.5
承認/Approved	検図/Checked	製図/Created	型番/Product number MBCF□-□-□ B15-2 (D ≥ 301)	
中根	大江	横田	作成日/Date 2019/06/26	3 / 3